



**BRIGGS & STRATTON**  
ENERGY SOLUTIONS

**PPDX26**

**BUILT FOR  
CERTAIN**



**POWERPROTECT+**

**RESIDENTIAL STANDBY GENERATOR SPECIFICATIONS**

OVERVIEW	
<b>Brand</b>	Briggs & Stratton
<b>Series Name</b>	PowerProtect <sub>+</sub>
<b>Model Name</b>	PPDX26
<b>Power, Standby (LP/NG) (kW)<sup>1</sup></b>	26 / 24
<b>Rated AC Voltage (Volts)<sup>1</sup></b>	120 / 240
<b>Rated Frequency (Hz)<sup>1</sup></b>	60
<b>Generator Breaker (Amps)</b>	125
<b>Operating Ambient Temperature (°C/ °F)</b> (no warmers installed)	-1 to 40 / 30 to 104
<b>Operating Ambient Temperature (°C/ °F)</b> (cold start battery, battery warmer, fuel regulator warmer and oil warmer installed)	-28 to 40 / -20 to 104
<b>Rated Amperage, Standby (LP/NG) (Amps)<sup>1</sup></b>	108.3 / 100
<b>Rated Power Factor</b>	1.0
Engine	
<b>Engine Brand/Manufacturer</b>	Vanguard
<b>Model Type</b>	M61
<b>Aspiration</b>	Naturally Aspirated
<b>Speed (RPM)</b>	3600
<b>Displacement (ci/cc)</b>	61 / 993
<b>Compression Ratio</b>	9.7:1
<b>Governor Type</b>	SAE J1444 Class B Frequency Regulation
<b>Bore &amp; Stroke (in/mm)</b>	3.37 x 3.41 / 85.5 x 86.5
<b>Cylinder Block</b>	Aluminum w Cast Iron Sleeve
<b>Valve Arrangement</b>	OHV

# PPDX26

**POWERPROTECT+**

RESIDENTIAL STANDBY GENERATOR SPECIFICATIONS



**BRIGGS & STRATTON**  
ENERGY SOLUTIONS

Engine	
Engine Cylinder Configuration	V
Number of Cylinders	2
Start Type	Automatic, Starter Motor
Air Filter Type	Dry
Low Oil Pressure Switch	Yes
Engine Oil Heater	Available as an Accessory
Rated Temperature (°F/°C)	77 / 25
Sound Rating	
Low Idle Mode Sound dB(A) <sup>2</sup>	62
Normal Operating Sound dB(A) <sup>2</sup>	67
Lubrication System	
Type	Full Pressure
Oil Capacity (oz/L)	78 / 2.31
Oil Filter (Quantity/Type)	1 / Cartridge
Recommended Oil	5W30 Full Synthetic
Electrical System	
Ignition System	Variable Timing
Battery Quantity	1
Battery Voltage (VDC)	12
Battery CCA (Amps)	540
Battery BCI Group Size	26 or 51
Starter Motor Voltage (VDC)	12
Fuel System	
Fuel Type	NG / LPV
Fuel Supply Line Inlet	3/4" NPT
Recommended Fuel, Lower Heating Value Minimum (MJ/m <sup>3</sup> / BTU/ft <sup>3</sup> )	NG: 34.3 / 904 LPV: 87.1 / 2338
Fuel Supply Pressure (mbar/in H <sub>2</sub> O)	NG: 9-17 / 3.5-7 LPV: 28-34 / 11-14
Fuel Consumption <sup>3</sup>	
No Load, NG (BTU/hr)	122,000
No Load NG (ft <sup>3</sup> /hr)	122
Half Load, NG (BTU/hr)	206,000

# PPDX26

POWERPROTECT+

RESIDENTIAL STANDBY GENERATOR SPECIFICATIONS



BRIGGS & STRATTON  
ENERGY SOLUTIONS

Fuel Consumption <sup>3</sup>	
Half Load, NG (ft <sup>3</sup> /hr)	206
Full Load, NG (BTU/hr)	323,000
Full Load, NG (ft <sup>3</sup> /hr)	323
No Load, LP (BTU/hr)	123,000
No Load, LP (ft <sup>3</sup> /hr)	49
No Load, LP (gal/hr)	1.4
Half Load, LP (BTU/hr)	235,000
Half Load, LP (ft <sup>3</sup> /hr)	94
Half Load, LP (gal/hr)	2.6
Full Load, LP (BTU/hr)	427,000
Full Load, LP (ft <sup>3</sup> /hr)	171
Full Load, LP (gal/hr)	4.7
Alternator Specifications	
Alternator Type	Synchronous, Self-Excited, Rotating Field
Alternator Manufacturer	B&S
Rated Frequency (Hz) <sup>1</sup>	60
Rated Phase <sup>1</sup>	1
Insulation Rating (Class)	H
Designed Temperature Rise (°C)	135
Bearing (Quantity/Type)	1 / Sealed
Number of Poles	2
Voltage Regulator	Brushed / Electronic
Motor Starting Capability (kVA)	65.5
Total Harmonic Distortion (THD), NL to FL (%)	< 5
Controls / Instrumentation	
Controller	GC-1033
Charger	Stand Alone
Starting	AMF or 2-wire
LCD Display with Fault Code Indications	Yes
Real Time Clock	Yes
Engine Hour Counter	Yes
Engine Runtime Scheduler	Yes

# PPDX26

**POWERPROTECT+**

RESIDENTIAL STANDBY GENERATOR SPECIFICATIONS



**BRIGGS & STRATTON**  
ENERGY SOLUTIONS

Controls / Instrumentation	
Low Oil Pressure Shutdown	Yes
High Temperature Shutdown	Yes
Other Features	
Battery Rack and Cables	Yes
Fuel Solenoid Valve	Yes
Integral Vibration Isolation	Yes
Oil Drain Extension	Yes
Operation and Installation Manual(s)	Yes
Enclosure	Aluminum
Enclosure Wind Speed Rating (mph)	186
Accessories	
Maintenance Kit	6872
Oil Warmer	6959
Fuel Regulator Warmer	6961
Battery Warmer	6960
Limited Warranty <sup>4</sup>	
Warranty: Generator, USA & Canada Emergency Stationary Use (Parts / Labor / Travel) – Years	10
Warranty: Enclosure, Surface Rust and Corrosion (Parts / Labor / Travel) – Years	1
Warranty: Enclosure, Rust Through (Parts / Labor / Travel) – Years	3
Warranty: Generator, USA & Canada Non-Emergency Stationary Use (Parts / Labor / Travel) – Years / Hours	10yr or 1000hr
Certifications	
UL	Yes
cUL	Yes
FCC	Yes
Massachusetts Plumbers and Gasfitters	Yes
NFPA 37	18" Installation Clearance from House <sup>5</sup>

# PPDX26

POWERPROTECT+

RESIDENTIAL STANDBY GENERATOR SPECIFICATIONS



BRIGGS & STRATTON  
ENERGY SOLUTIONS

## Weights & Dimensions

<b>Assembled Dimensions (Length x Width x Height) (in / mm)</b>	46 x 27 x 28 / 1180 x 691 x 721
<b>Assembled Weight (lbs / kg)</b>	545 / 247
<b>Packaged Dimensions (Length x Width x Height) (in / mm)</b>	48 x 33 x 37 / 1222 x 838 x 945
<b>Packaged Weight (lbs / kg)</b>	605 / 275
<b>Outline and Pad Layout Drawing</b>	80141033

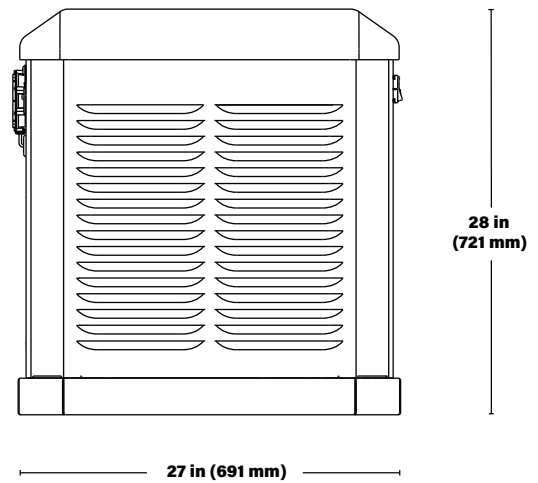
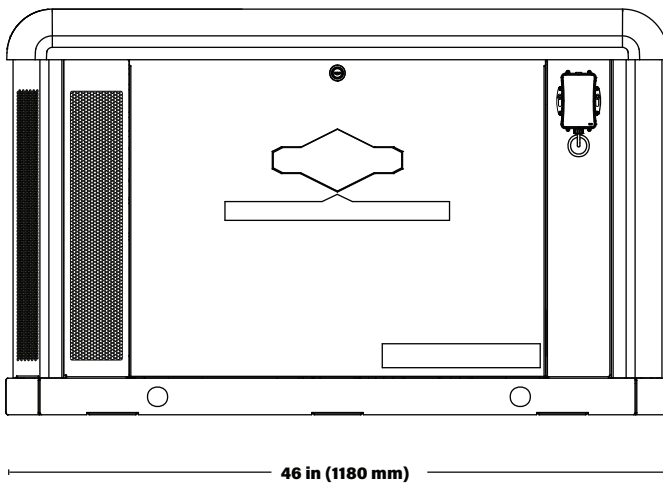

<sup>1</sup> This generator is rated in accordance with UL (Underwriters Laboratories) 2200 (stationary engine generator assemblies) and CSA (Canadian Standards Association) standard C22.2 No. 100-14 (motor and generators).

<sup>2</sup> Per ISO 3744. Sound level measurement at other locations around generator may differ depending on installation, based on lowest microphone at 7m. Normal operation based on average household usage.

<sup>3</sup> Fuel consumption rates are estimated based on normal operating conditions. Generator operation may be greatly affected by elevation and the cycling operation of multiple electrical appliances — fuel flow rates may vary depending on these factors.

<sup>4</sup> See operator's manual or [energy.briggsandstratton.com](http://energy.briggsandstratton.com) for complete warranty details.

<sup>5</sup> Listing and labeling to NFPA 37 per Southwest Research Institute.

<sup>6</sup> Of domestic and foreign components.

Briggs & Stratton has a policy of continuous product improvement and reserves the right to modify its specifications at any time and without prior notice.

This standby generator is not for Prime Power applications.

Please visit [energy.briggsandstratton.com](http://energy.briggsandstratton.com) for the latest information.

BS1543 - 04/01/26

**BRIGGS & STRATTON**  
POST OFFICE BOX 702  
MILWAUKEE, WI 53201 USA

Copyright © 2026 Briggs & Stratton. All rights reserved.